

SN Sauger zum Aufstecken auf Rohr

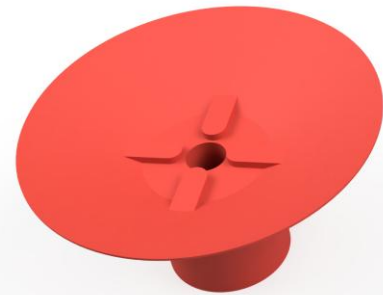
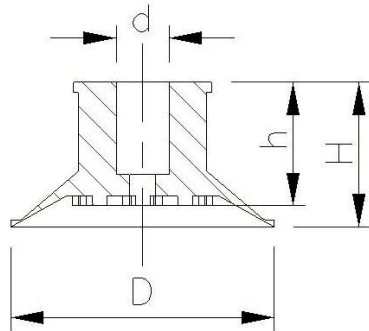

Abbildung: SNR 40

SN – TN Sauger						
Best.Nr.	D	d	H	h	Anlagefläche	F [N]
SNR 10	10	5	10	7,5	-	
SNR 15	15	5	12	10	-	
SNR 30	30	6,5 8 10	21	19	siehe Abb.	42
SNR 40	40	8 10 12	21	19	siehe Abb.	63
SNR 50	50	10 12 15	24	19	siehe Abb.	
SNR 70	70	16	34	24	8 radial	126
TNR 70	70	8	43	30	-	
SNR 80/1	80	8 16 24	45	40	11	
SNR 80/2	80	8 16 24	45	40	3	
SNRB 80/1	80	10	45	40	3	
SNR 100	100	16	43	33	2	203
SNDR 140	140	25	51	48	2	